



## CORDIS FLOW CONTROLLER



*Precise, linear flow control within a closed-loop system with ultra high resolution and repeatability*

<b>Medium</b>	Clean, dry, non-corrosive gases
<b>Wetted Material</b>	<i>Sensor: Polyamide, Manifold: Anodized Aluminum, Valves: DVP: Stainless Steel, PPS, EVP: ENP Brass, Regulated Supply: ENP Brass IP65 Housing: Polycarbonate</i>
<b>Valve Type</b>	Normally-Closed Proportional
<b>Operating Flow Range</b>	Minimum: 0 to 15 sccm Maximum: 0 to 6 l/min
<b>Flow Range Sensors</b>	0 to 0.03 l/min, 0 to 0.2 l/min, 0 to 0.5 l/min, 0 to 1 l/min, 0 to 4 l/min, 0 to 6 l/min
<b>Max. Inlet</b>	60 psig
<b>Typical Response Time</b>	<50 ms (application dependent)
<b>Accuracy</b>	≤2% of Full Scale
<b>Resolution</b>	≤25 mV
<b>Max. Hysteresis</b>	≤1%
<b>Repeatability</b>	≤1%
<b>Linearity</b>	≤1%
<b>Pressure Drop</b>	≤14" H2O
<b>Port Size</b>	1/8" NPT, G1/8
<b>Temperature Range</b>	<i>Proportional Valve: 32° to 120°F</i>
<b>Mounting Attitude</b>	Any
<b>Filtration</b>	40 micron
<b>More Details</b>	<a href="http://clippard.com/link/cordis">clippard.com/link/cordis</a>



*Clippard's proven DVP and EVP proportional valves provide fast, stable control of flow*

New to the Cordis family is the highly anticipated Electronic Flow Controller. Different from the Cordis Pressure Controller, the Flow Controller utilizes an extremely fast reacting mems technology sensor upstream of Clippard's proportional valve. Adding the optional DR-2 Regulator for accurate and precise pressure control makes for a very small, compact package by eliminating the need for an external regulated supply. Unlike other mass flow controllers that require a 30-minute warm-up period, large differential pressures, limited flow ranges, the Cordis Flow Controller requires less than one minute warm-up, Pressure drop is equal to or less than 14" H2O, and flow ranges as low as 0 to 30 sccm. The Cordis Flow Controller comes with standard control options such as 0.2 to 10 VDC, 4.32 to 20 mA and 3.3 VDC Serial. This flow controller allows for the same customer custom changes within their application as the Cordis Pressure Controller. This controller also comes in an IP65 housing for light industrial applications when needed.

The Cordis uses a micro-controller, integral flow sensor, DR-2 regulator and one proportional valve. Supply gas is connected to the regulator which accurately maintains pressure to the flow sensor and the Clippard EVP or DVP proportional valve. As command is increased, the comparative circuit opens the valve to allow flow to pass through the onboard flow sensor which in turn provides an active feedback signal for the micro-controller to satisfy the flow setpoint in the process. If at any point the flow sensor detects a value higher or lower than the setpoint command, the proportional valve will modulate more or less output to maintain a stable and accurate control of flow in the process.

- Compact size and weight
- ≤14" H2O pressure drop
- <50 ms response time
- ≤25 mV resolution
- Multiple low flow ranges
- OEM style card unit or IP65 housed

<b>Voltage</b>	15 to 24 VDC
<b>Current Draw</b>	≤250 mA max.
<b>Protection Rating</b>	IP65 (housed unit only)
<b>Warm-Up Period</b>	<1 minute
<b>Signal/Command</b>	<i>Electrical: 0.2 to 10 VDC or 4.32 to 20 mA Serial: 3.3 VDC</i>
<b>Turndown Ratio</b>	50:1



## ORDERING INFORMATION

Model	Type	Porting	Signal/Command	Regulated Supply	Supply Pressure	Calibrated Flow Range
<b>CFC-</b> Flow Control	<b>C</b> Card Unit	<b>F</b> 1/8" NPT	<b>E</b> 0.2 to 10 VDC	<b>-A</b> No Regulator	<b>A</b> 5 to 10 psig	<b>A</b> 0 to 0.03 l/min
	<b>H</b> Housed Unit	<b>G</b> G1/8	<b>R</b> 3.3 VDC Serial	<b>-B</b> Clippard DR-2 Regulator	<b>B</b> 11 to 20 psig	<b>B</b> 0 to 0.2 l/min
			<b>I</b> 4.32 to 20 mA		<b>C</b> 21 to 30 psig	<b>C</b> 0 to 0.5 l/min
			<b>Example Part No.</b> CFC-CFE-BAC		<b>D</b> 31 to 40 psig	<b>D</b> 0 to 1 l/min
					<b>E</b> 41 to 50 psig	<b>E</b> 0 to 4 l/min
					<b>F</b> 51 to 60 psig	<b>F</b> 0 to 6 l/min

### Accessories

- CPCH-C1** Actuation Cable, 8-Pin, 6'
- CPCH-C2** 3.3 VDC Serial Cable, 3'
- CPCH-CA6** Power Cord, 6' (*card unit only*)

### CFC-C Card Unit

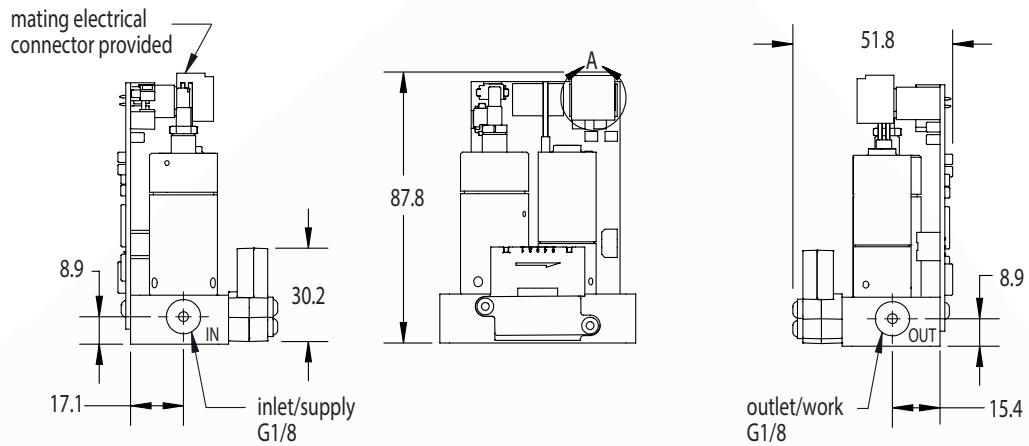

### CFC-H Housed Unit

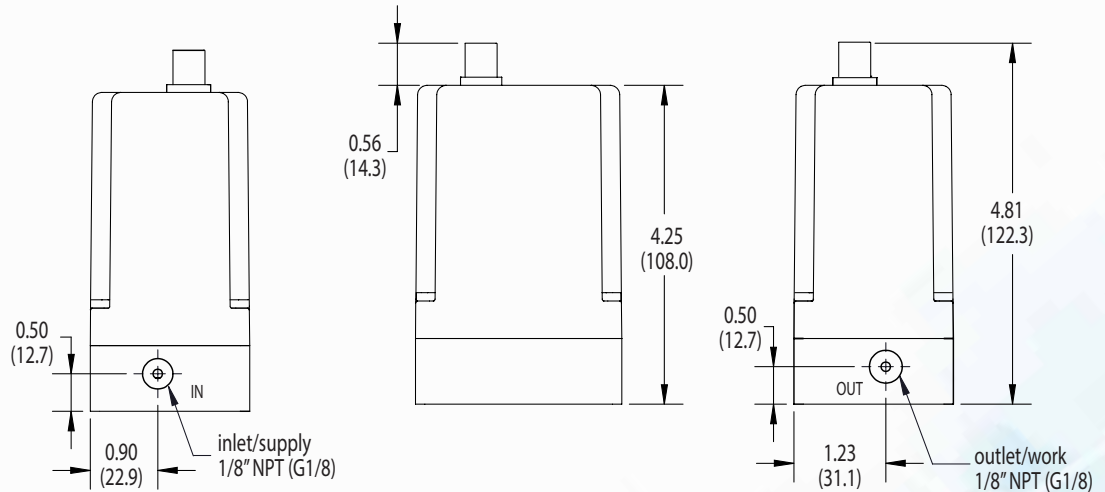

877-245-6247 | [clippard.com](http://clippard.com)

CLIPPARD INSTRUMENT LABORATORY, INC. • ISO 9001 • TDS 9.20  
For warranty and disclaimer information, visit [clippard.com/warranty](http://clippard.com/warranty)

